

RCB 型低NOxリジェネレーティブバーナ

RCB LOW NOx REGENERATIVE BURNER SYSTEM



Available Heat**85%以上**の省エネルギー(CO₂削減)バーナシステムです。
Energy saving (CO₂ emission reduction) burner system achieved the Available Heat :
85% or over.

特長

FEATURES

AH (Available Heat) 85%以上も可能

AH (Available Heat): 85% or over

$$\text{AH} = \frac{(\text{燃料発熱量} - \text{炉排出熱})}{\text{燃料発熱量}} \times 100 (\%)$$

$$\text{AH} = \frac{(\text{Combustion calorific value} - \text{Furnace discharge heat})}{\text{Combustion calorific value}} \times 100 (\%)$$

温度効率80%以上も可能

Temperature efficiency: 80% or over

$$\text{温度効率} = \frac{\text{予熱空気温度}}{\text{燃焼排ガス温度}} \times 100 (\%)$$

$$\text{Temperature efficiency} = \frac{\text{Preheat air temperature}}{\text{Combustion exhaust gas temperature}} \times 100 (\%)$$

超低NOx技術を採用

Ultra-low NOx technology adopted

蓄熱器の形状が自在

Regenerator models in a flexible variety of styles

各種燃料に対応

Available to a variety of fuels

制御原理

CONTROL PRINCIPLE

一方のバーナが燃焼している間、他方のバーナは排ガス口の役割をはたします。排ガスは蓄熱器で結露しない温度まで廃熱回収され系外に排出します。燃焼空気は蓄熱器で受熱し、超高温(排ガスの80%以上)に予熱されバーナに供給されます。所定のサイクル時間が経過すると、燃焼と排気が切り替わります。

While one of the burners is burning, the other burner will work as an exhaust outlet. The exhaust gas is discharged from the system after the waste heat of the gas is recovered so that the temperature of the gas will be lowered to the extent that there will be no condensation in the regenerator. The combustion air receives heat from the regenerator. Therefore, the combustion air will be preheated to a super-high temperature (i.e., 80% of the temperature of the exhaust gas or over) before the combustion air is supplied the burner. When the preset cycle time elapses, the burners exchange their roles of combustion and exhaustion.

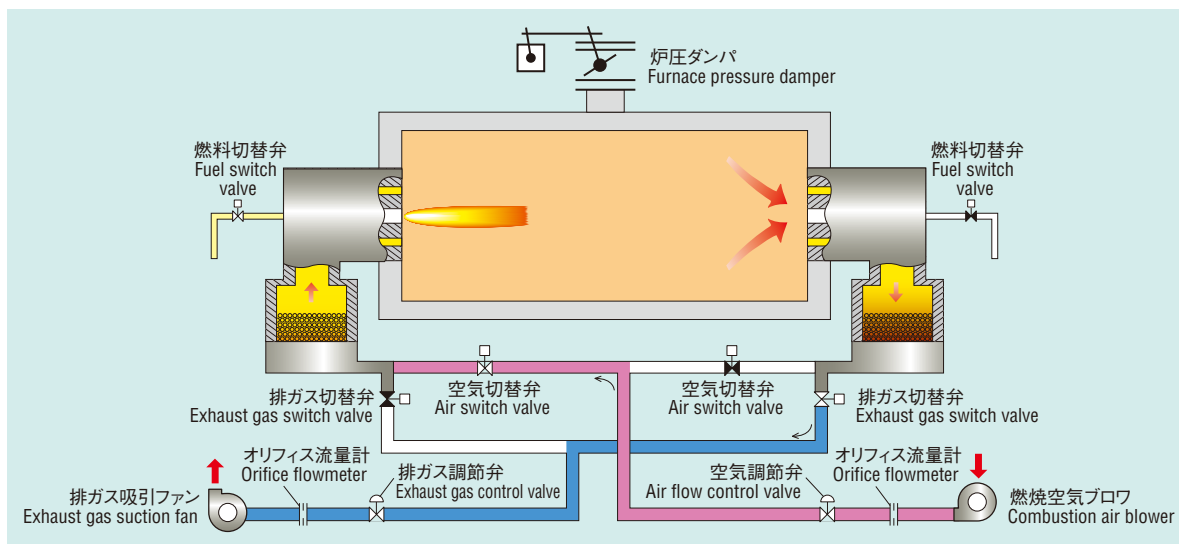

省エネルギー性:AH(Available Heat)比較

ENERGY-SAVING PERFORMANCE : AH(Available Heat) COMPARISON

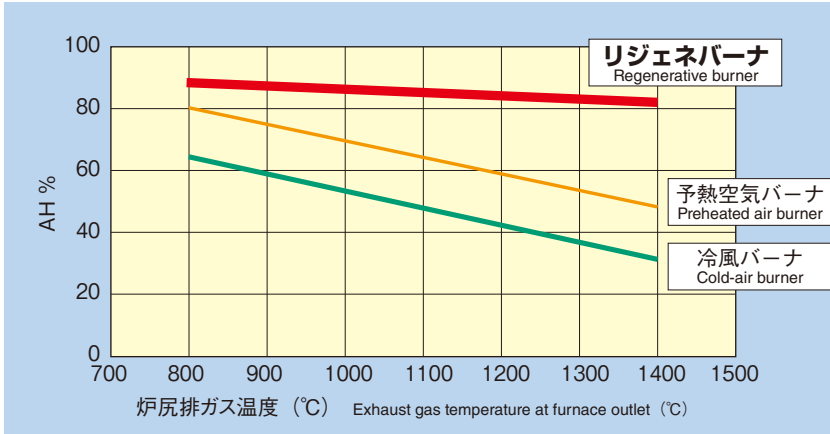

〈計算条件〉

リジェネバーナ 燃料:LNG
空気比:1.10
排ガス吸引率:80%
温度効率:85%

予熱空気バーナ 予熱空気温度:450°C

冷風バーナ 燃焼空気温度:20°C

<Calculation Conditions>

Regenerative burner Fuel:LNG
Air ratio:1.10
Exhaust gas suction rate:80%
Temperature efficiency:85%

Preheated air burner Preheated air temperature:450°C

Cold-air burner Combustion air temperature:20°C

AH (Available Heat) の差は炉温が高いほど大きくなります。
The higher the furnace temperature is, the greater the difference in AH will be.

燃料節約率

FUEL SAVING RATE

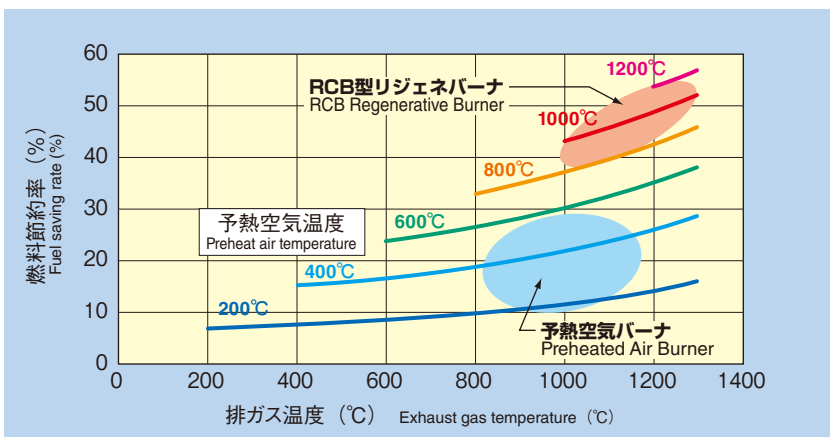

〈計算条件〉

燃料:LNG
空気比:1.10

<Calculation Conditions>

Fuel:LNG
Air ratio:1.10

予熱空気温度と温度効率

PREHEAT AIR TEMPERATURE AND TEMPERATURE EFFICIENCY

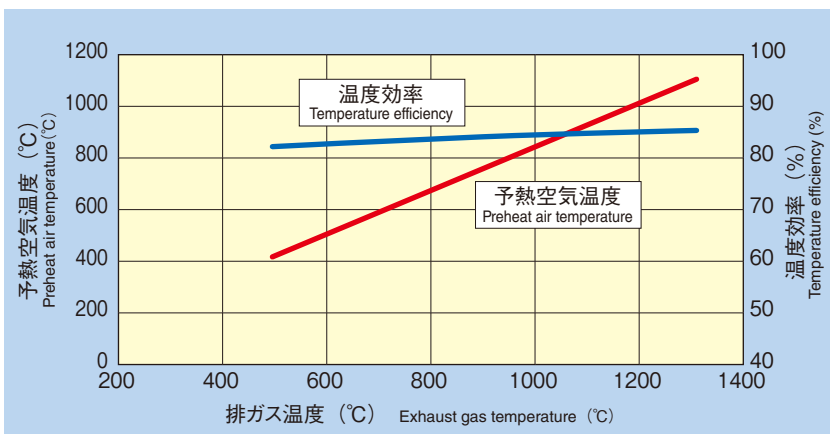

$$\text{温度効率} = \frac{\text{予熱空気温度}}{\text{燃焼排ガス温度}} \times 100 (\%)$$

〈計算条件〉









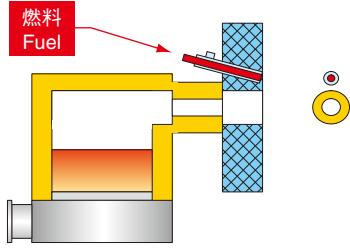

燃料:LNG
空気比:1.10
排ガス吸引率:80%
蓄熱器出口排ガス温度:120°C

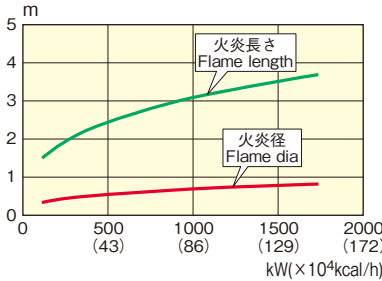
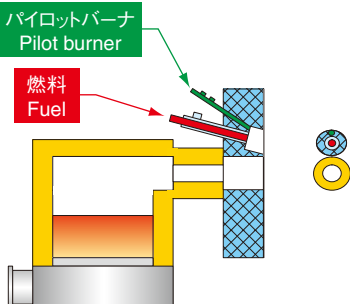
<Calculation Conditions>

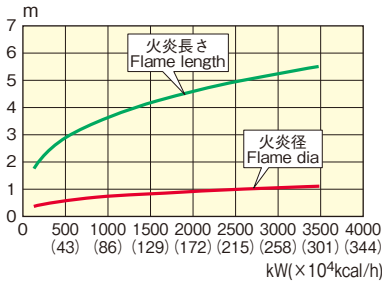
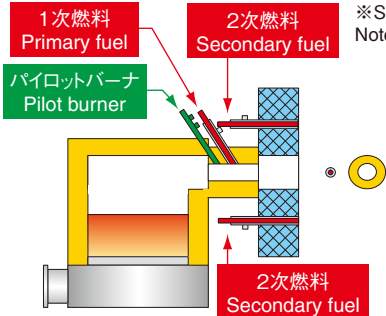
Fuel:LNG
Air ratio:1.10
Exhaust gas suction rate:80%
Exhaust gas temperature at regenerator outlet:120°C

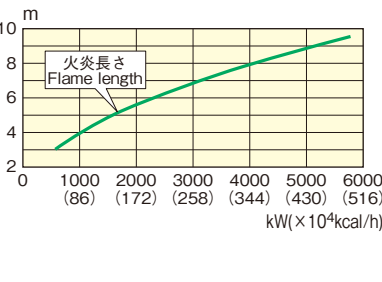
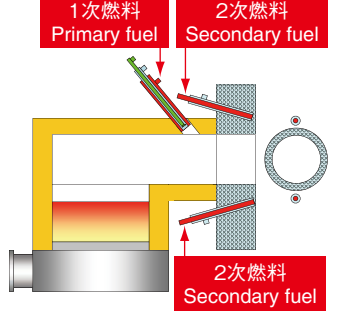
機種一覧表

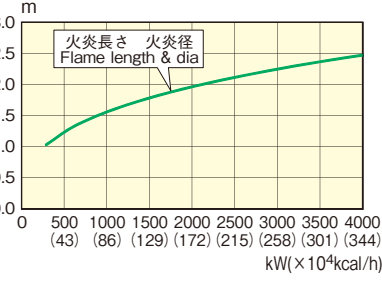
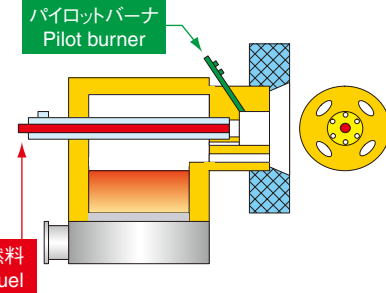
LINEUP OF MODELS

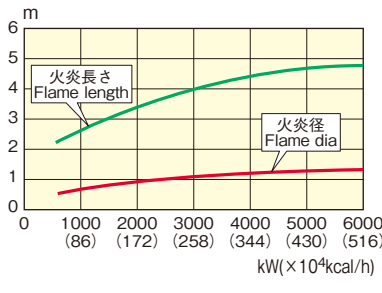
	構造 Construction	火炎形状 Flame size
RCB-STD型 用途 Use 鉄鋼加熱炉 鍛造加熱炉 アルミ溶解炉 熱処理炉 取鍋予熱装置 他 Reheating furnace Forging furnace Aluminum melting furnace Heat treatment furnace Ladle preheater etc.	 <p>燃料 Fuel</p> <p>点火方式 Ignition system メインダイレクト点火 Main direct ignition</p> <p>ガスノズルユニット Gas nozzle unit</p> 	 <p>火炎長さ Flame length</p> <p>火炎径 Flame dia</p> <p>kW (× 10⁴kcal/h)</p>
RCB-STP型 用途 Use 鉄鋼加熱炉 鍛造加熱炉 アルミ溶解炉 熱処理炉 取鍋予熱装置 他 Reheating furnace Forging furnace Aluminum melting furnace Heat treatment furnace Ladle preheater etc.	 <p>パイロットバーナ Pilot burner</p> <p>燃料 Fuel</p> <p>点火方式 Ignition system パイロットバーナ点火 Pilot burner ignition</p> <p>RP-15K型パイロットバーナ RP-15K Pilot burner</p> 	 <p>火炎長さ Flame length</p> <p>火炎径 Flame dia</p> <p>kW (× 10⁴kcal/h)</p>
RCB-FD型 (STN型) 用途 Use 鉄鋼加熱炉 鍛造加熱炉 アルミ溶解炉 Reheating furnace Forging furnace	 <p>1次燃料 Primary fuel</p> <p>2次燃料 Secondary fuel</p> <p>パイロットバーナ Pilot burner</p> <p>2次燃料 Secondary fuel</p> <p>※STN型はガスノズルユニットを搭載 Note) STN: Gas nozzle unit</p> <p>点火方式 Ignition system パイロットバーナ点火 Pilot burner ignition</p> <p>RP-15K型パイロットバーナ RP-15K Pilot burner</p> 	 <p>火炎長さ Flame length</p> <p>kW (× 10⁴kcal/h)</p>
RCB-SF型 (ショートフレイム型) (Short flame type) 用途 Use 均熱炉 鉄鋼加熱炉 鍛造加熱炉 アルミ溶解炉 熱処理炉 取鍋予熱装置 他 Holding furnace Reheating furnace Forging furnace Aluminum melting furnace Heat treatment furnace Ladle preheater etc.	 <p>1次燃料 Primary fuel</p> <p>2次燃料 Secondary fuel</p> <p>2次燃料 Secondary fuel</p> <p>点火方式 Ignition system パイロットバーナ点火 Pilot burner ignition</p> <p>ガスノズルユニット(パイロット内蔵型) Gas nozzle unit (Built-in pilot type)</p> 	 <p>火炎長さ 火炎径 Flame length & dia</p> <p>kW (× 10⁴kcal/h)</p>
RCB-FH型 用途 Use 鉄鋼加熱炉 鍛造加熱炉 アルミ溶解炉 熱処理炉 焼鈍炉 取鍋予熱装置 他 Reheating furnace Forging furnace Aluminum melting furnace Heat treatment furnace Annealing furnace Ladle preheater etc.	 <p>パイロットバーナ Pilot burner</p> <p>燃料 Fuel</p> <p>点火方式 Ignition system パイロットバーナ点火 Pilot burner ignition</p> <p>RP-15K型パイロットバーナ RP-15K Pilot burner</p> 	 <p>火炎長さ Flame length</p> <p>火炎径 Flame dia</p> <p>kW (× 10⁴kcal/h)</p>

各機種への対応燃焼容量

ADAPTABLE FIRING RATE DEPENDENT ON MODELS

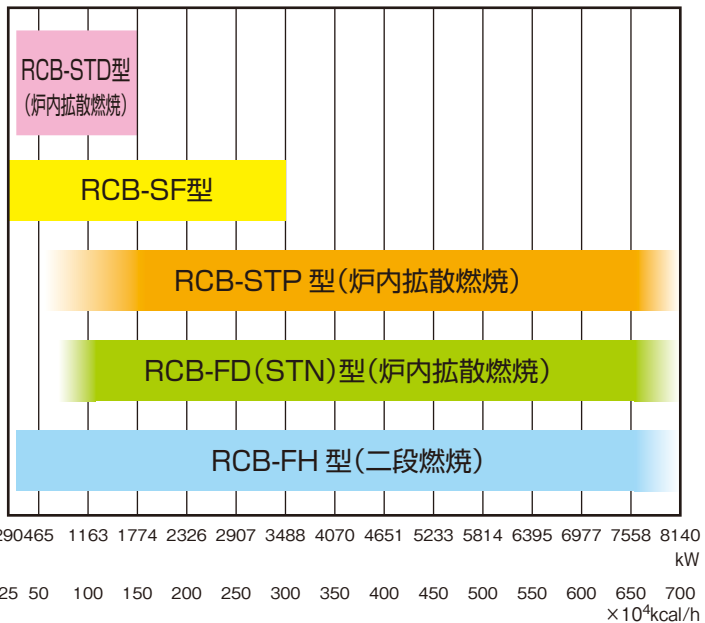

型番選定表

LINEUP OF MODEL NUMBER

型番 Model	炉内温度別最大燃焼量 [kW(×10 ⁴ kcal/h)] Maximum firing rate dependent on furnace temperatures		
	900℃	1100℃	1300℃
RCB-□-8	617(53)	531(46)	465(40)
RCB-□-10	926(80)	796(68)	698(60)
RCB-□-12	1235(106)	1061(91)	930(80)
RCB-□-20	1852(159)	1592(137)	1395(120)
RCB-□-22	2084(179)	1791(154)	1570(135)
RCB-□-25	2315(199)	1990(171)	1744(150)
RCB-□-35	3087(266)	2653(228)	2326(200)
RCB-□-40	3859(332)	3316(285)	2907(250)
RCB-□-60	5403(465)	4642(399)	4070(350)
RCB-□-75	6946(597)	5969(513)	5233(450)
RCB-□-80	7718(664)	6632(570)	5814(500)

上記の燃焼量は、エア圧力4kPa、空気比1.1、炉内温度1300℃を基準としています。
The above firing rates are based on air pressure of 4kPa, excess air ratio of 1.1, and a furnace temperature of 1300°C.

NOx特性 NOx Characteristics

炉温とNOx特性

Furnace Temperature and NOx Characteristics

燃料負荷率：100%
空気比：1.1
排気ガス吸引率：85%

Burner load: 100%
Air ratio: 1.1
Exhaust gas suction rate: 85%

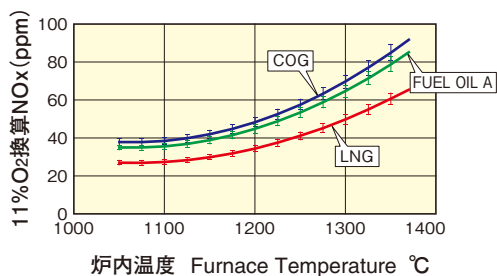

- ※1. A重油のデータはFuel Nを含んでおりません。他燃料ご使用の際は、お問い合わせください。
※2. A重油のデータは高圧空気スプレーヤ使用時のものです。
- Notes)1. The data of the fuel oil A do not include FUEL N. In case of using other fuel, contact us.
2. The data of the fuel oil A : Sprayed with compressed air.

炉温とNOx特性

Furnace Temperature and NOx Characteristics

燃料:LNG、空気比:1.1 Fuel: LNG Excess air ratio: 1.1

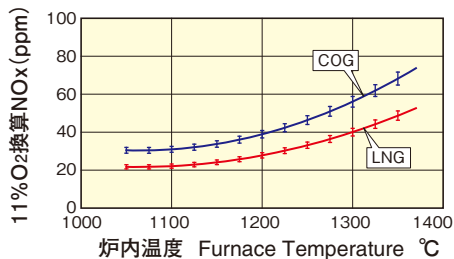

炉温とNOx特性

Furnace Temperature and NOx Characteristics

燃料:LNG、空気比:1.1 Fuel: LNG Excess air ratio: 1.1

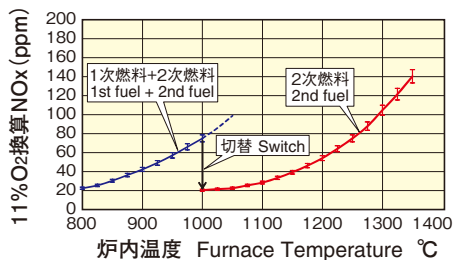

炉温とNOx特性

Furnace Temperature and NOx Characteristics

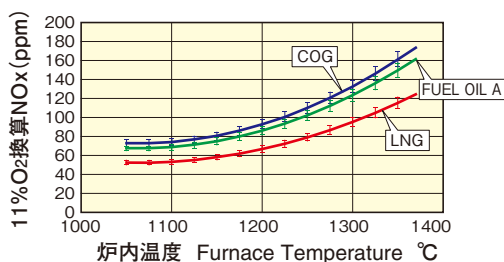

燃料負荷率：100% Burner load: 100%
空気比：1.1 Air ratio: 1.1
排気ガス吸引率：85% Exhaust gas suction rate: 85%

- ※1. A重油のデータはFuel Nを含んでおりません。他燃料ご使用の際は、お問い合わせください。
※2. A重油のデータは高圧空気スプレーヤ使用時のものです。
- Notes)1. The data of the fuel oil A do not include FUEL N. In case of using other fuel, contact us.
2. The data of the fuel oil A : Sprayed with compressed air.

実施例(加熱炉)

EXAMPLES OF APPLICATIONS (REHEATING FURNACE)

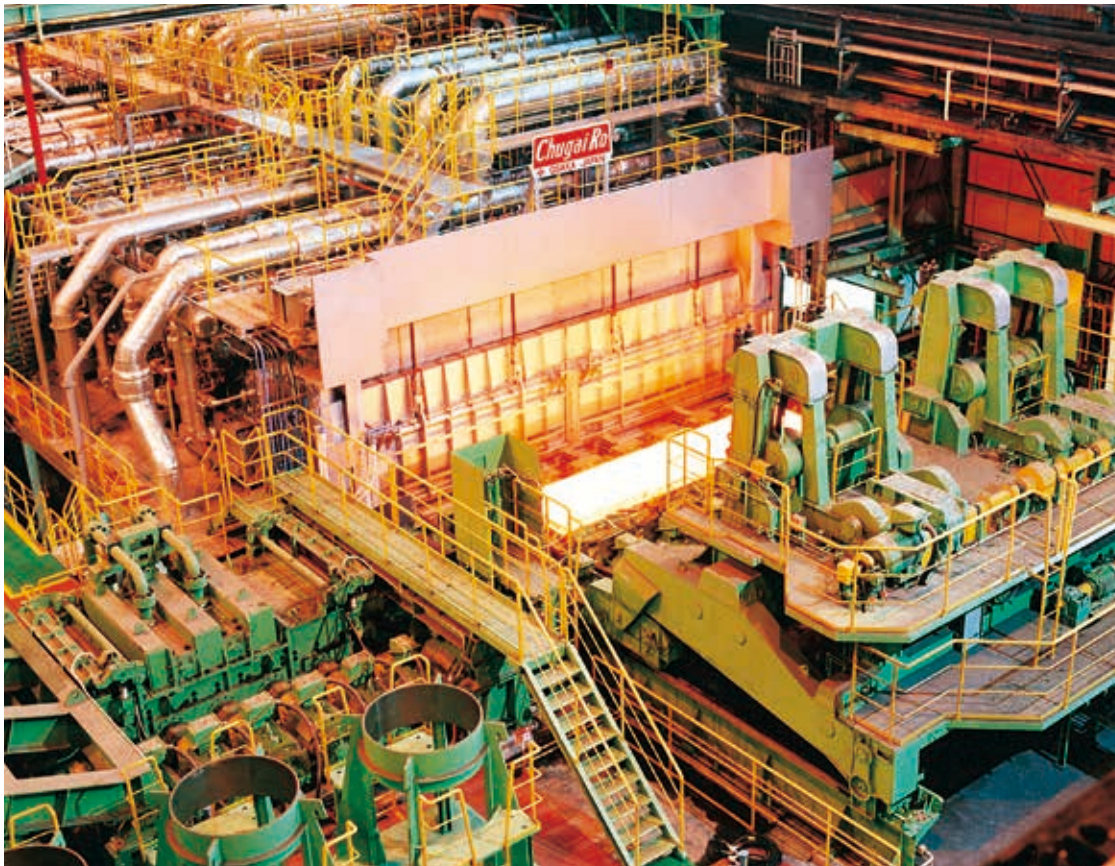

対応機種

Available burner

RCB-STD

RCB-STP

RCB-FD

RCB-SF

RCB-FH



This burner is below model.

RCB-FD

(写真のモデル)

実施例(取鍋予熱装置)

EXAMPLES OF APPLICATIONS (LADLE PREHEATER)



対応機種

Available burner

RCB-STP

RCB-STD

RCB-SF

RCB-FH

RCB-ES



実施例(鍛造炉)

EXAMPLES OF APPLICATIONS (FORGING FURNACE)

サイド/
バック取付
Mounting
on side
or back

対応機種
Available
burner

RCB-FH

RCB-STP

RCB-STD

RCB-SF

RCB-ES



RCB-SF型短炎リジェネバーナ
RCB-SF Swirl Short Flame Regenerative Gas Burner

天井取付
Mounting
on roof

対応機種
Available
burner

RCB-STD

RCB-STP

RCB-SF



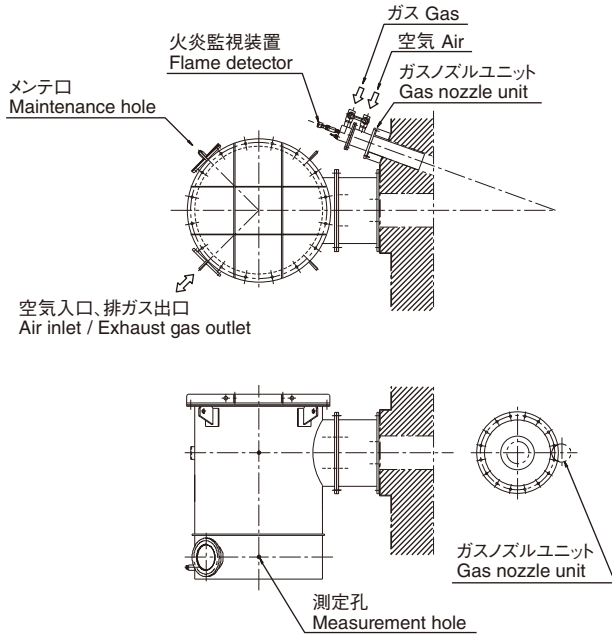

温度分布シミュレーション
Simulation of temperature distribution

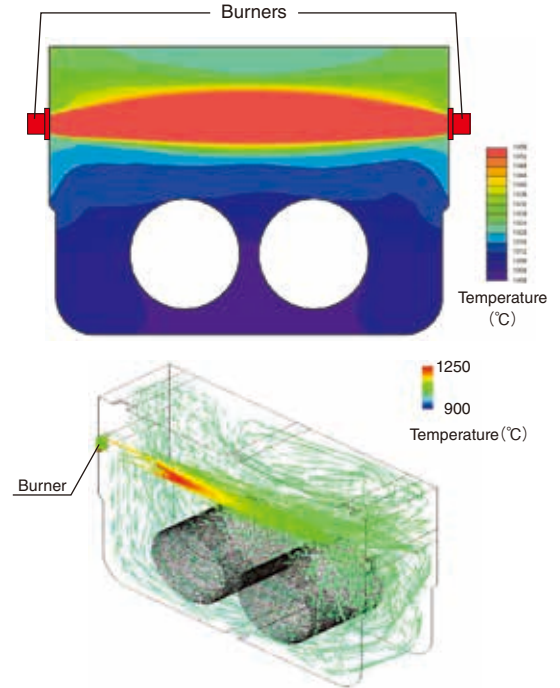

蓄熱器 Ball box

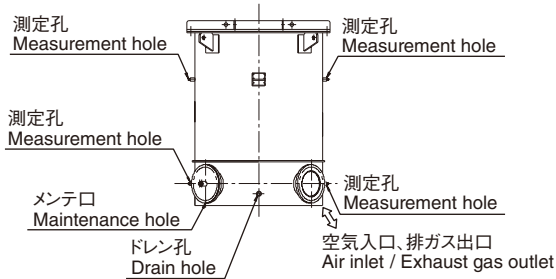

温度分布シミュレーション
Simulation of temperature distribution

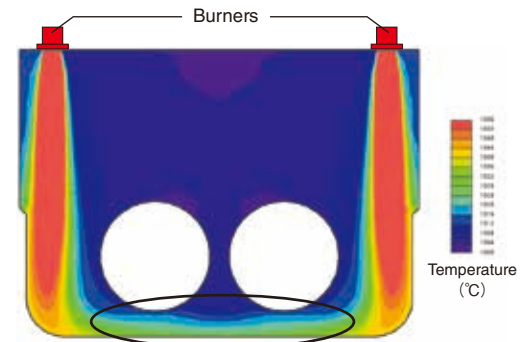

下部の温度分布が良好
The distribution of the bottom is uniform.

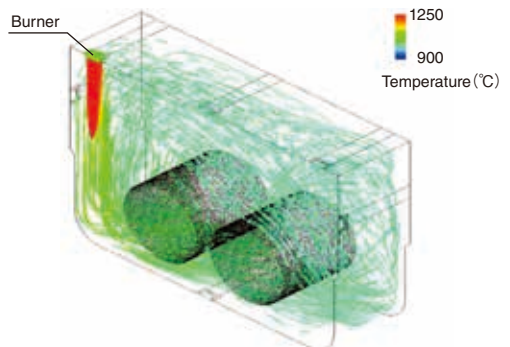
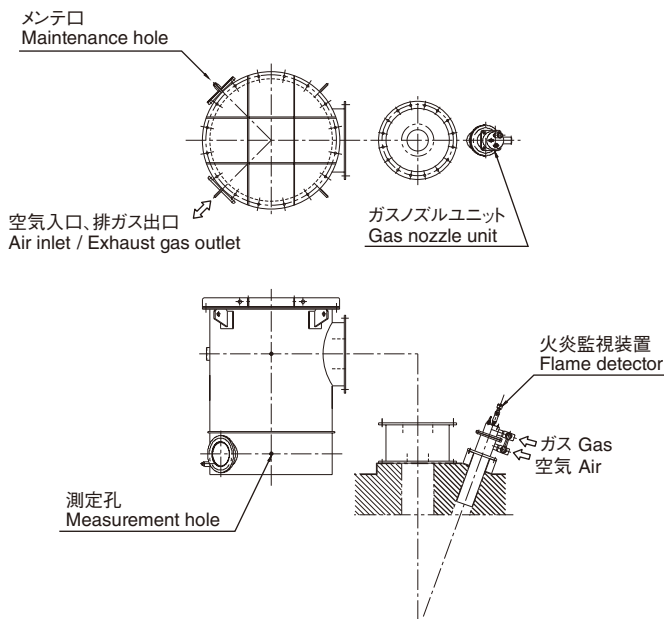

実施例(アルミ溶解炉)

EXAMPLES OF APPLICATIONS (ALUMINUM MELTING FURNACE)

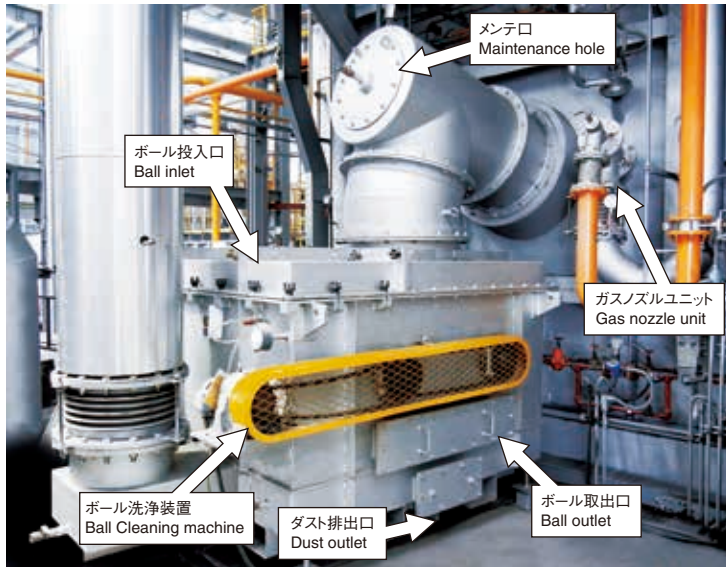

アルミ溶解炉専用リジェネバーナ
REGENERATIVE BURNER FOR ALUMINUM MELTING FURNACE

RCB-STP型燃烧火炎
RCB-STP Combustion flame



新構造採用と当社独自開発のメディア洗浄装置搭載でメンテナンス性の向上を実現
Adoption of a new structure and incorporating a unique media washing device developed by Chugai Ro has improved maintenance.

従来バーナ火炎ノズル
Flame nozzles of a conventional burner



ダストが詰まると...
When nozzles are clogged with dust...



メンテナンスが必要になります。
Maintenance was required.

アルミ溶解炉専用リジェネバーナなら簡単なメンテナンスで常にクリーンな状態を維持できます。
This burners can always be kept clean with simple maintenance.

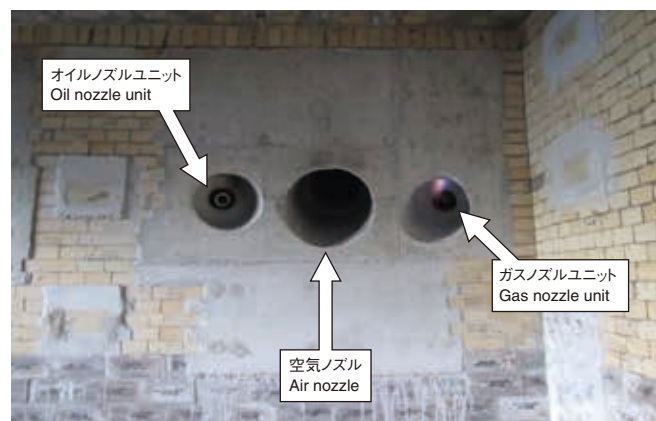

オイル／ガス両用リジェネバーナ<特許取得済>
Oil/Gas Dual Use Regenerative Burner <Patented>

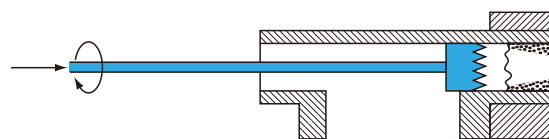

クリーニングしやすい新構造を採用。<特許取得済>
A new structure that facilitates cleaning has been adopted. <Patented>

■RCB-STP(ガス専焼)(Gas burner)

EASY MAINTENANCE

特許取得済

蓄熱器内のダストを効果的に取り除きます。
Ball mixer removes the dust in the ball box effectively.



攪拌機
Ball mixer

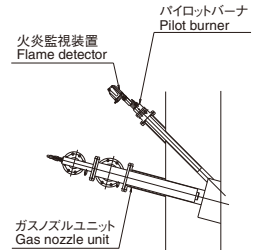
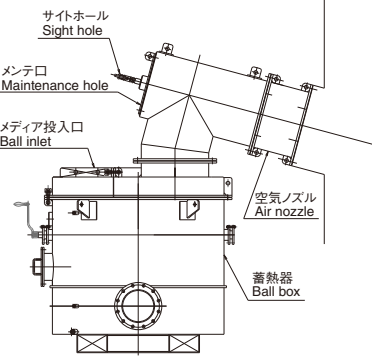
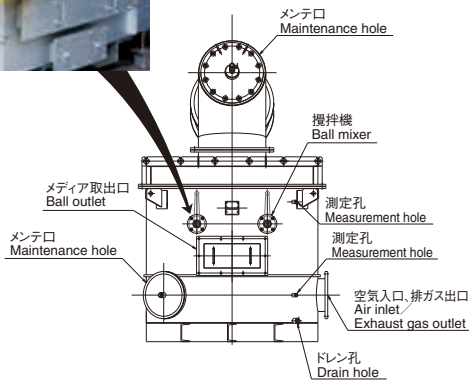

■RCB-STP DUAL(オイル、ガス切替専焼)(Oil/gas switching burner)

EASY MAINTENANCE

特許取得済

蓄熱器内のダストを効果的に取り除きます。
Ball mixer removes the dust in the ball box effectively.



攪拌機
Ball mixer

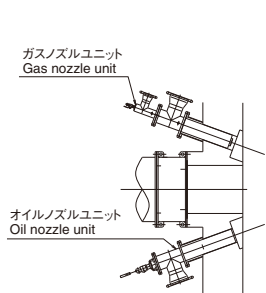
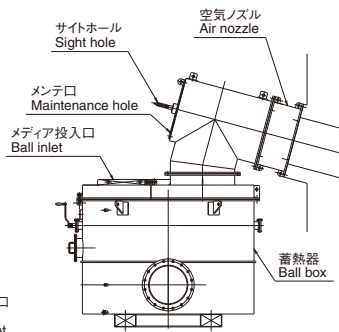
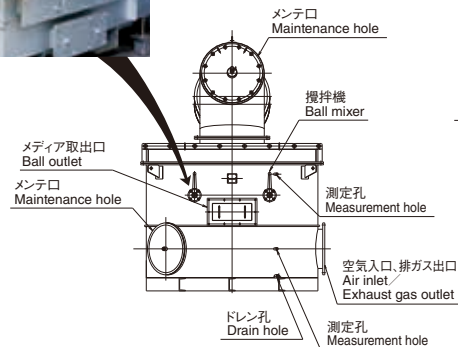

■RCB-FH

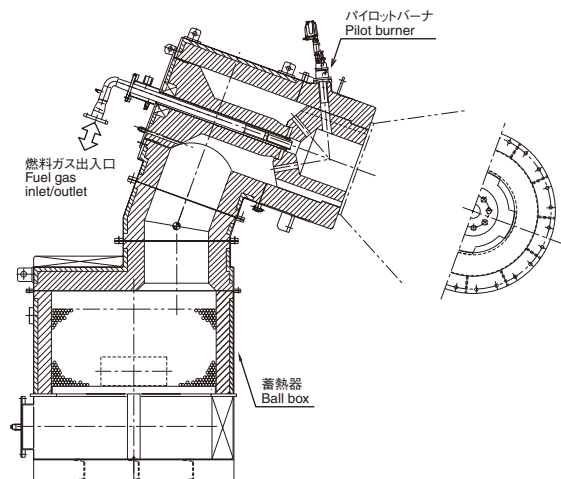
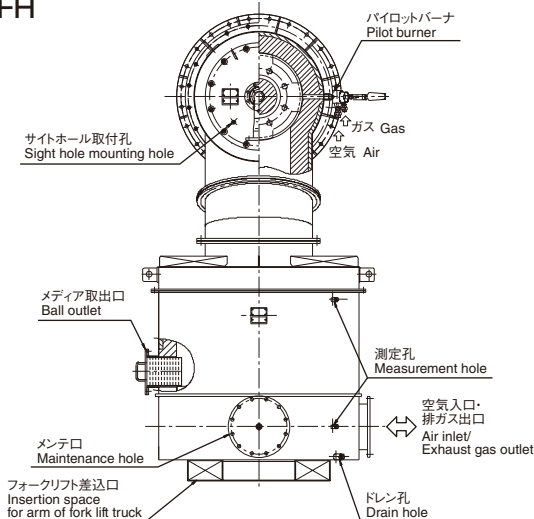

RCB-SF型短炎リジェネバーナ

RCB-SF SWIRL SHORT FLAME REGENERATIVE GAS BURNER

短炎化、低NOx、安定した燃焼性

Short flame, low NOx emissions, and stable combustibility

強力な旋回流によりリジェネバーナの短炎化を実現! 炉形状の自由度の向上に寄与!
低NOx性と安定した燃焼性を両立したリジェネバーナです!

The short flame of this regenerative burner has been realized by adopting a strong rotating flow. This contributes to improvement in flexibility of the furnace shape. This regenerative burner realizes both low NOx emissions and stable combustibility.

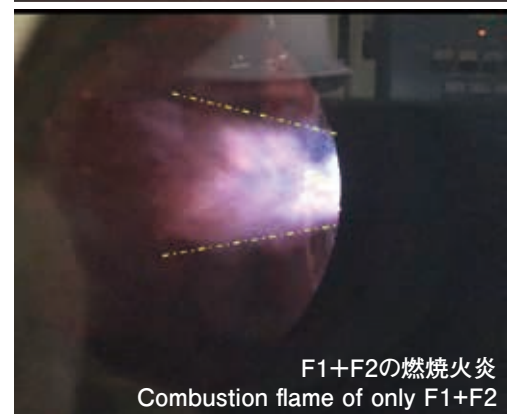
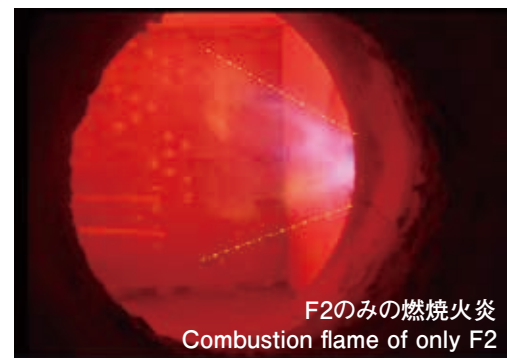
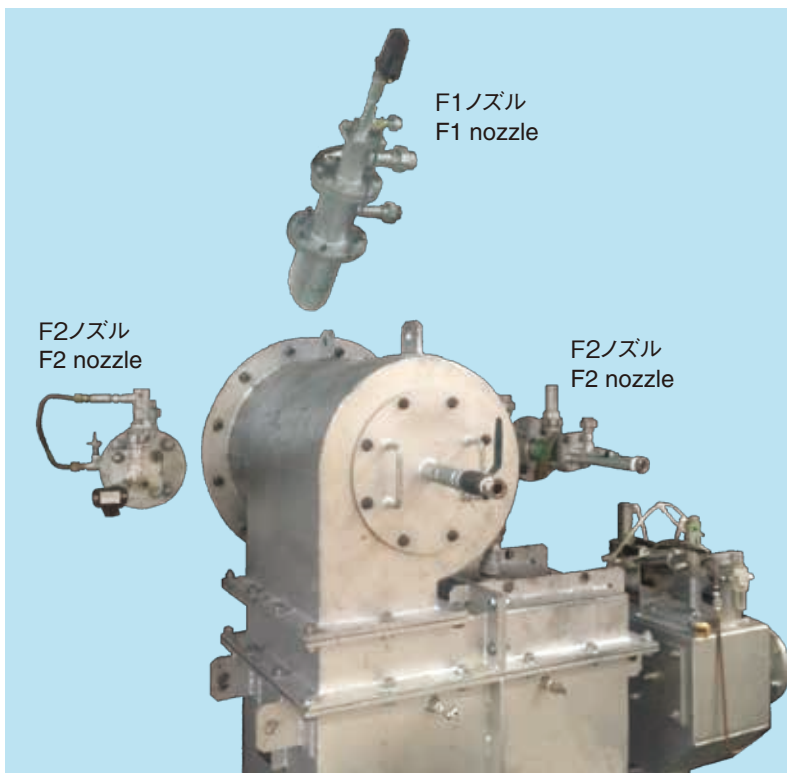

特長

FEATURES

① 短炎

- 強力な旋回流で短炎を形成します
- 対向設置したリジェネバーナの火炎の干渉を防ぐことができます。
- 炉内壁を効率良く加熱して、放射熱による高効率な熱伝達を行います。
- サイドはもちろんのこと、ルーフにも取り付けが可能です。
- 炉幅が狭い、炉高が低い、被加熱物までの距離が短いなど、従来では取り付け困難であった場所にも最適です。

② 低NOx性、安定した燃焼性

- 独自のノズル構造により、低NOx性と安定した燃焼性を実現します。

① Short flame

- The short flame is formed by a strong rotating flow.
- Interference by regenerative burners disposed opposite to each other can be prevented.
- The inside wall of the furnace is heated efficiently to transmit heat very effectively by radiant heat.
- This burner can be mounted not only on a side wall but also on a roof.
- This is best in a case where a burner could not be easily mounted in the past, for example, in a case where the furnace is narrow or low in height, or the distance to the object heated is too short.

② Low NOx emissions and stable combustibility

- Low NOx emissions and stable combustibility are realized by Chugai Ro's own nozzle structure.

用途

APPLICATIONS

- 鉄鋼加熱炉
- 非鉄金属溶解保持炉
- 鍛造加熱炉
- 熱処理炉 etc.
- Roof burners for iron and steel reheating furnaces (especially for soaking areas)
- Holding furnaces for nonferrous metals
- Forging reheating furnaces
- Heat treating furnaces, etc.

バーナ仕様

SPECIFICATION EXAMPLES

- 型式：RCB-SF-□
- 燃料：LNG、LPG、その他各種ガス
- Model: RCB-SF-□
- Fuel: LNG, LPG, or other gases

バーナ構造

BURNER CONSTRUCTION

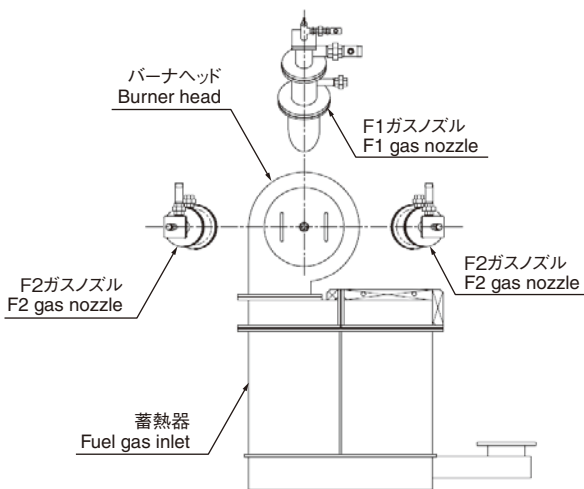

NOx特性

NOx CHARACTERISTIC

【条件】 燃焼容量：581kW，燃料：LNG，空気比：1.1

[Conditions] Combustion capacity: 581 kW, fuel: 13A city gas, excess air ratio: 1:1

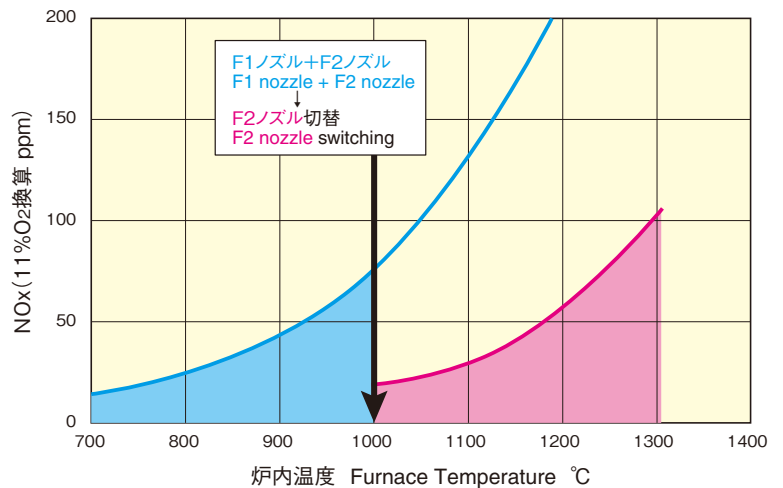

火炎形状

FLAME FIGURE

バーナ型式 Burner model	火炎長 Flame length (m)	火炎径 Flame diameter (m)
RCB-SF	1.3	1.3
RCB-FH	2.2	0.5
RCB-STP	3.0	0.7

火炎長が従来(STP型)の **1/2以下**
The flame length is below half that of the conventional model (STP).

炉壁や材料への火炎の干渉を防止
炉形状の自由度が向上
The furnace walls and materials are prevented from interference with the flame.
Flexibility of the furnace shape is improved.

【条件】 燃焼容量：581kW，燃料：LNG，空気比：1.1，炉内温度：1300°C

[Conditions] Combustion capacity: 581 kW, fuel: 13A city gas, excess air ratio: 1:1, Furnace Temperature: 1300°C

RCB-ES型ハイスピードセルフリジェネバーナ RCB-ES HIGH SPEED SELF-REGENERATIVE BURNER

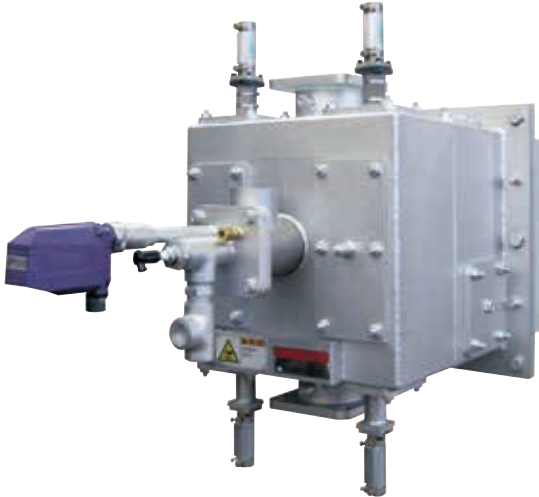

長炎
Long flame

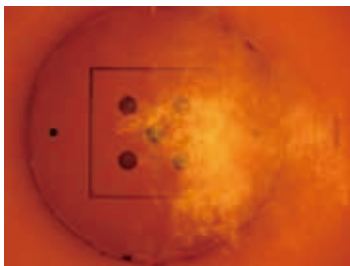

短炎
Short flame

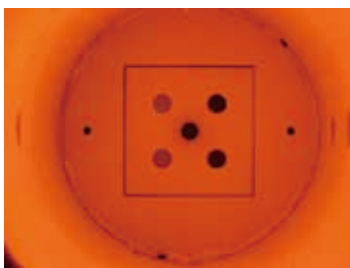

特長 FEATURES

- ①超小型、小容量
 - ・直火型セルフリジェネバーナでは世界最小クラス(容量比、当社調べ)を実現
 - ・独立弁タイプの空気・排ガス切替弁を内蔵
 - ・燃料の連続供給が可能で、燃料切替弁が不要
 - ②バリエブルフレーム特性
 - ・火炎形状が自由自在なため、炉形状や操業条件に合わせることが可能
 - ・モード切替により、燃焼状態が変化
 - ③高速火炎
 - ・高速火炎で炉内雰囲気攪拌し、炉内温度分布の均一性を向上
- ①Ultra-compact and small capacity
 - ・The world's smallest class direct frame type self-regenerative burner realized (by volume ratio according to our research)
 - ・Independent valve type air/exhaust gas selector valve incorporated.
 - ・Continuous fuel supply is possible, no fuel selector valve required.
 - ②Variable flame
 - ・Adjustable according to furnace configuration and operating conditions since the flame pattern can be freely changed.
 - ・Combustion state changes according to mode switching.
 - ③High-speed flame
 - ・Increase in uniformity of furnace temperature distribution by agitating furnace atmosphere with high-speed flame.

構造説明 CONSTRUCTION

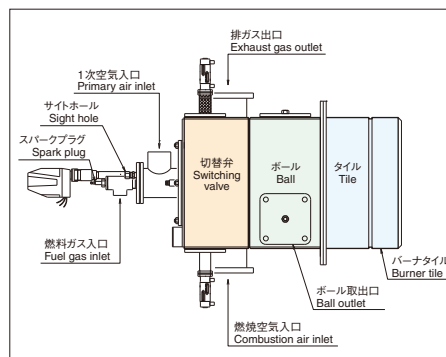

バーナ仕様 BURNER SPECIFICATION

バーナ型式 Burner model	燃焼容量 Firing rate	空気比 Excess air ratio	燃料ガス圧力 Gas Pressure	燃焼空気圧力 Air pressure	炉内温度 Furnace temperature
RCB-ES-125K	145kW	1.1	1.5kPa	7.0kPa	1,300°C
RCB-ES-250K	290kW				
RCB-ES-500K	580kW				

バーナ形状

BURNER DIMENSIONS

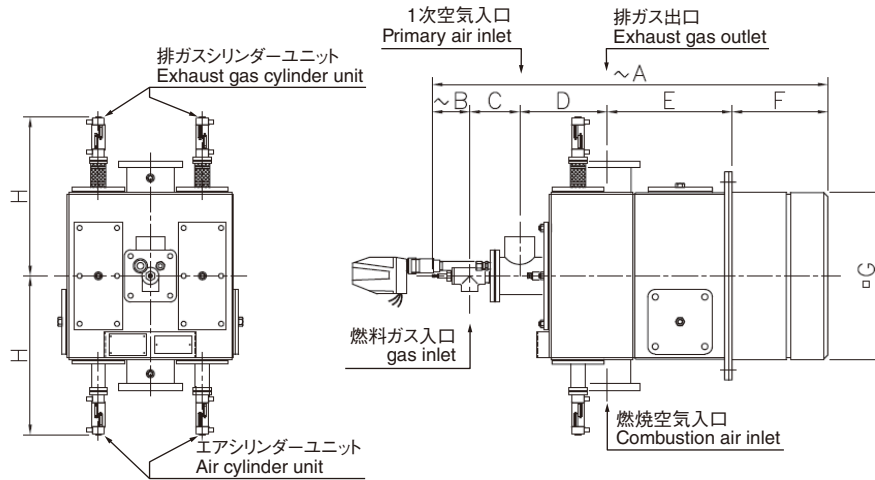

バーナ型式 Burner model	A	B	C	D	E	F	G	H
RCB-ES-125K	890	90	115	195	290	200	320	341
RCB-ES-250K	973	113	120	210	300	230	400	381
RCB-ES-500K	1143	113	165	260	325	280	550	466

バーナ特性

BURNER CHARACTERISTICS

【条件】バーナ型式：RCB-ES-250K，燃焼容量：290kW，燃料：13A都市ガス，空気比：1.1，炉内温度：1100℃
[Conditions] Combustion capacity: 290 kW, fuel: 13A city gas, excess air ratio: 1:1, Furnace Temperature: 1100℃

火炎形状

Flame pattern

短炎モード時 1500mm～
長炎モード時 2000mm

Short flame mode 1500mm～
Long flame mode 2000mm

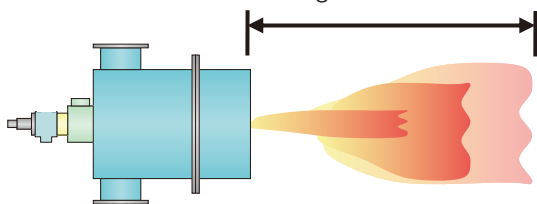

NO_x特性（長炎モード）

NO_x characteristics (long flame mode)

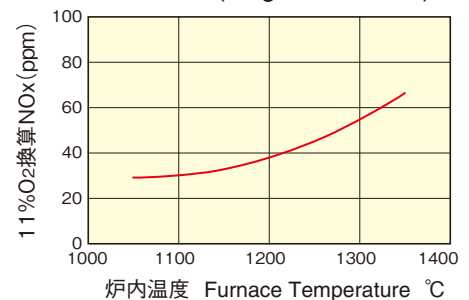

セミセルフリジェネレーティブバーナ SEMI-SELF REGENERATIVE BURNER

特長

FEATURES

- 温度効率80%以上
- 小型設備への設置も可能
- 配管がシンプル
- Temperature efficiency 80% or higher
- Also allowed to be installed onto small equipment
- Piping is simple

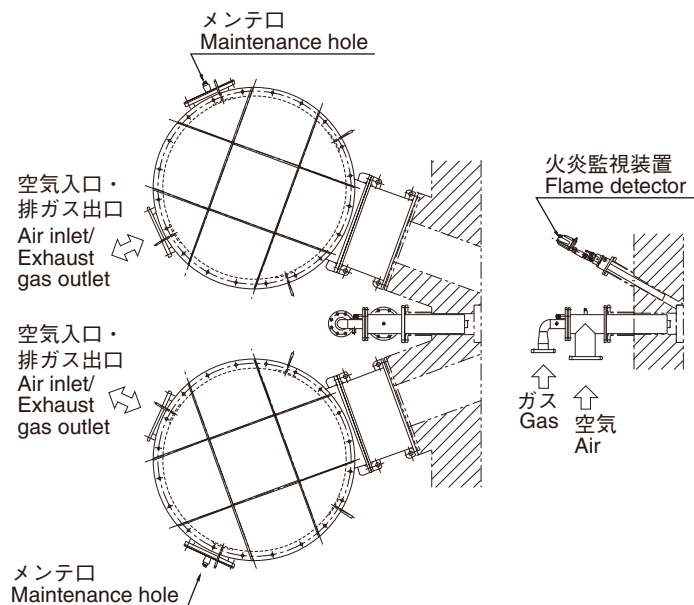

実施例

EXAMPLES OF APPLICATIONS

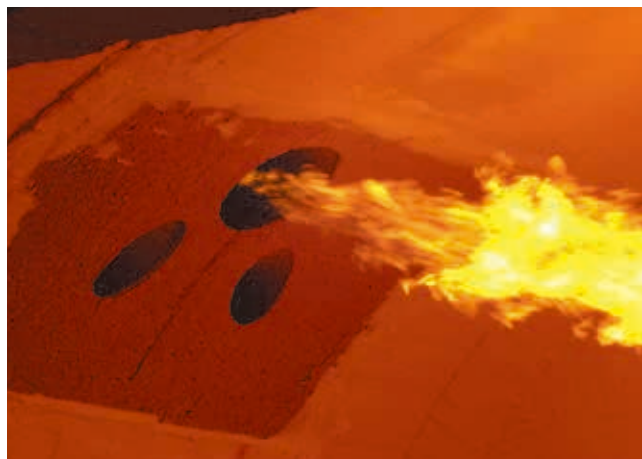
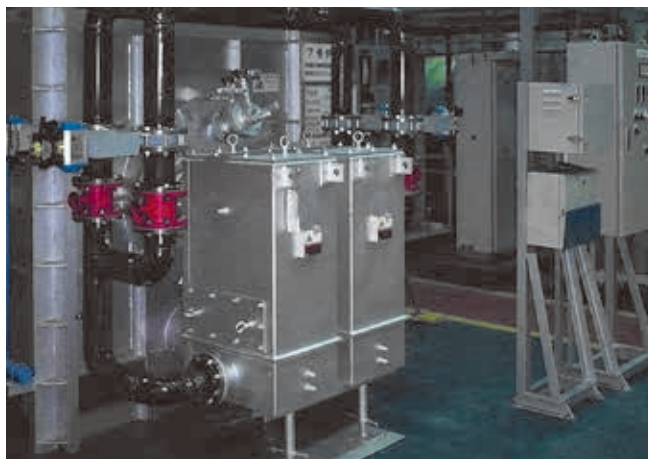

TECV型三方向切替弁
TECV 3WAY CYCLE VALVE



リジェネバーナ専用開発された三方向切替弁です。
従来2方向切替弁に比べ
省スペース、省コストを実現します。

This is a three-way selector valve developed exclusively for regeneration burner.
This saves space and reduces cost more than conventional two-way selector valve.

流体耐熱温度: 400°C
リーク量: 0.1%以下
Fluid heatproof temperature: 400°C
Amount of leak: 0.1% or less

取付寸法
INSTALLATION

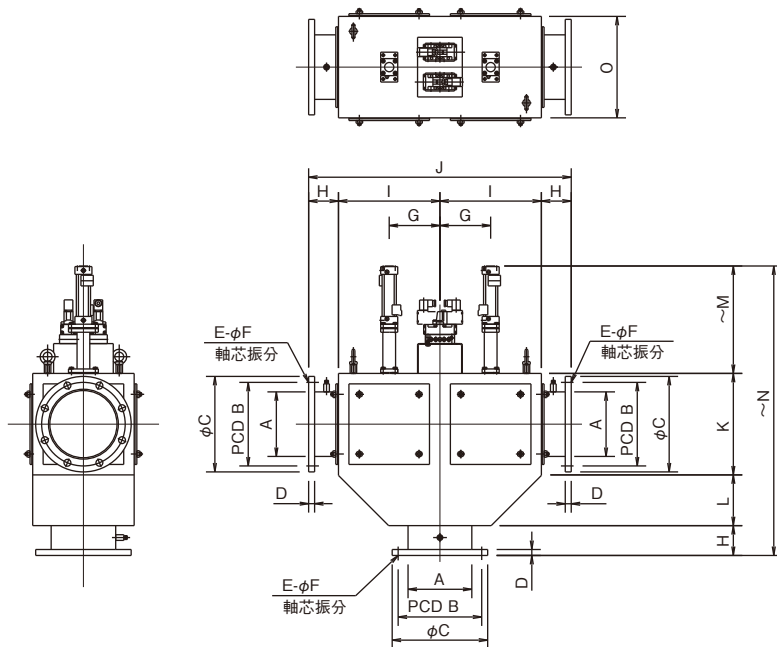

型番 Model	A	B	C	D	E	F	G	H	I	J	K	L	M	N	O
TECV-100	100A	165	200	16	8	19	105	100	210	620	210	105	231	646	210
TECV-125	125A	200	235	16	8	19	125	100	250	700	250	125	231	706	250
TECV-150	150A	230	265	18	8	19	140	100	280	760	280	140	278	798	280
TECV-200	200A	280	320	20	8	23	170	100	340	880	340	170	360	970	340
TECV-250	250A	345	385	22	12	23	200	100	400	1000	400	200	369	1069	400
TECV-300	300A	390	430	22	12	23	225	100	450	1100	450	225	452	1227	450
TECV-350	350A	435	480	24	12	25	250	110	500	1220	500	250	452	1302	500
TECV-400	400A	495	540	24	16	25	280	110	560	1340	560	280	542	1482	560
TECV-450	450A	555	605	24	16	25	315	110	630	1480	630	315	642	1687	630

仕様
SPECIFICATIONS

高圧空気: 0.4MPa
電磁弁作動電源: 100~200V
【付属品】
フィルターレギュレータ、近接スイッチ
※上記以外の仕様の際は、お問い合わせください。

Compression air: 0.4MPa
Solenoid valve operating power source:
100~200V

【Accessories】
Filter regulator
Proximity switch

Notes) Please consult us about requirements other than the above specifications.



制御方法

METHOD OF COMBUSTION CONTROL

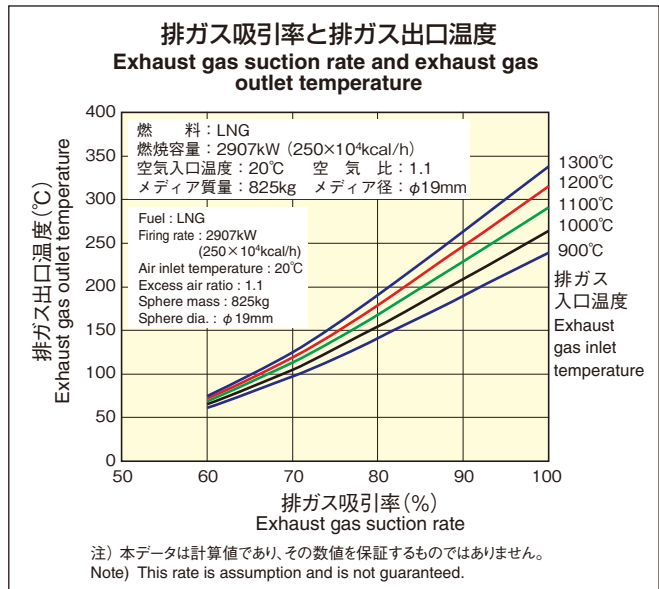
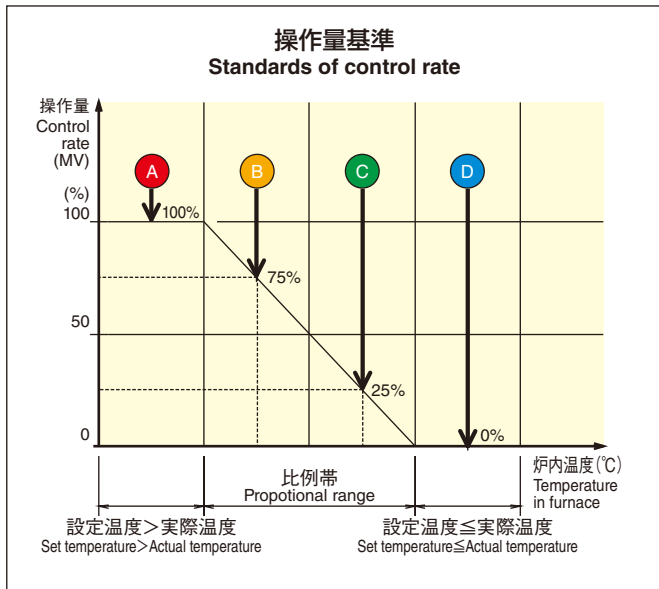

流量制御(FIC) Flow rate control

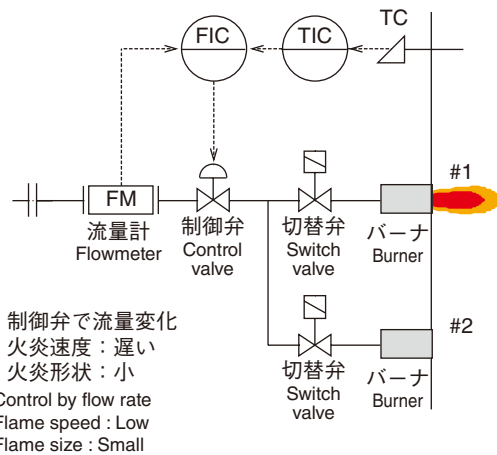
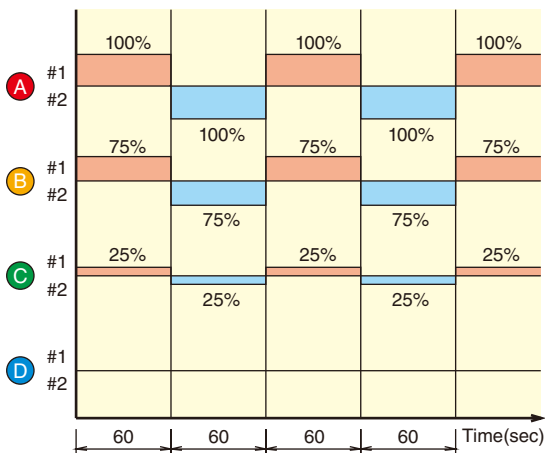

時間比例制御 Time-proportional control

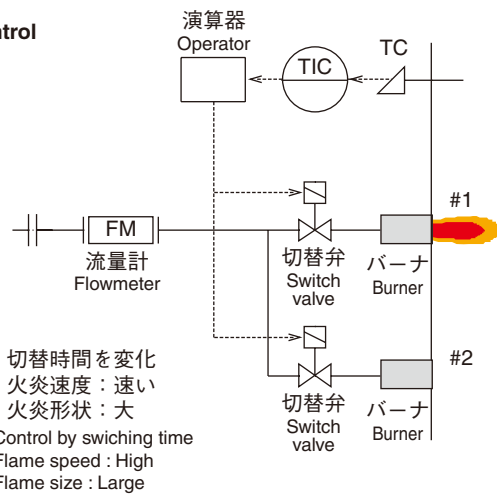
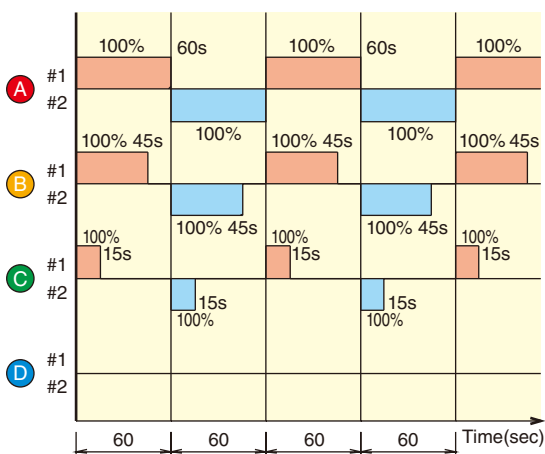

RCB-STP型リジェネレーティブガスバーナ用配管フローシート PIPING FLOW PLAN FOR RCB-STP REGENERATIVE GAS BURNER

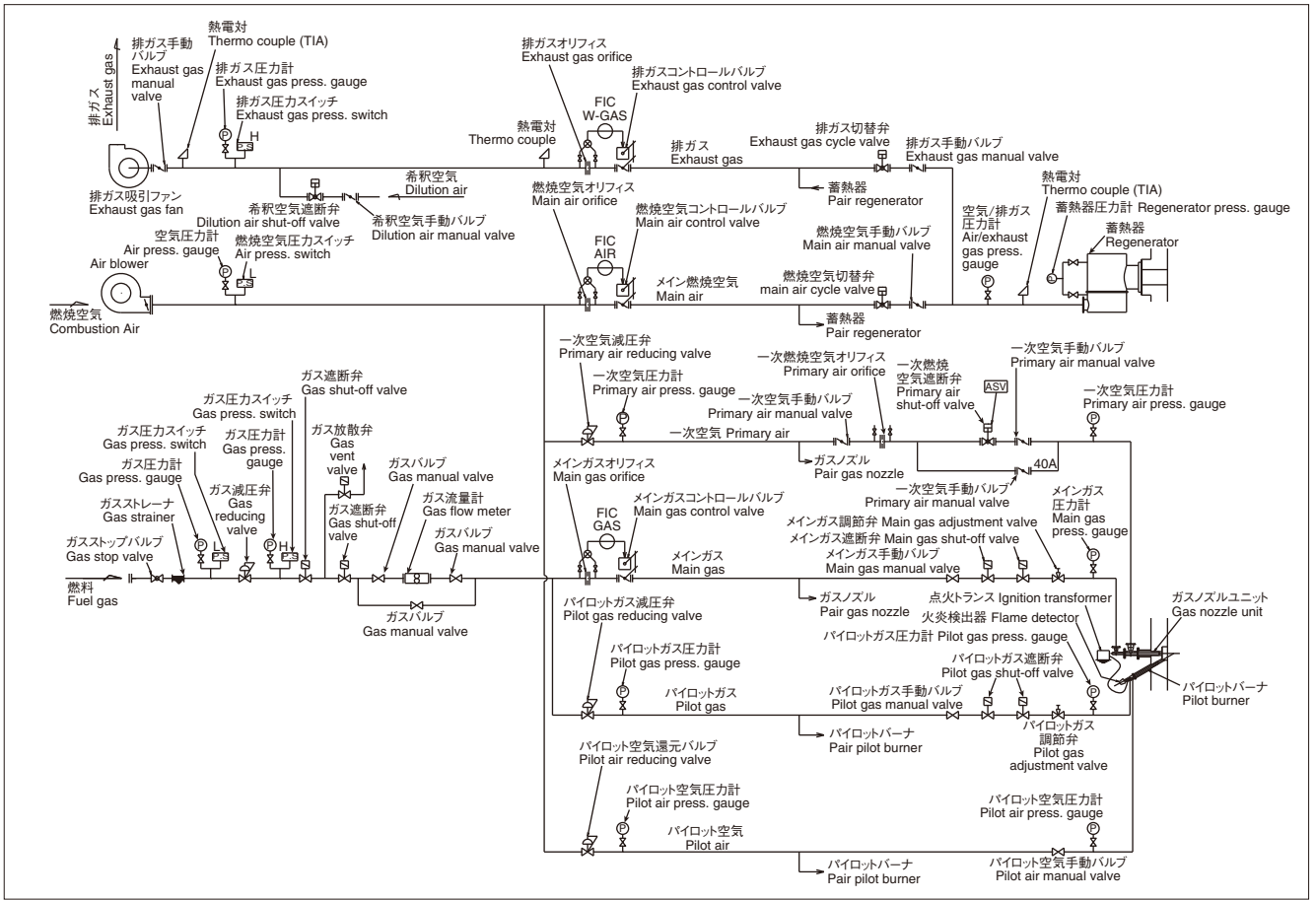

RCB-STD型セミセルフリジェネレーティブガスバーナ用配管フローシート PIPING FLOW PLAN FOR RCB-STD SEMI-SELF REGENERATIVE GAS BURNER

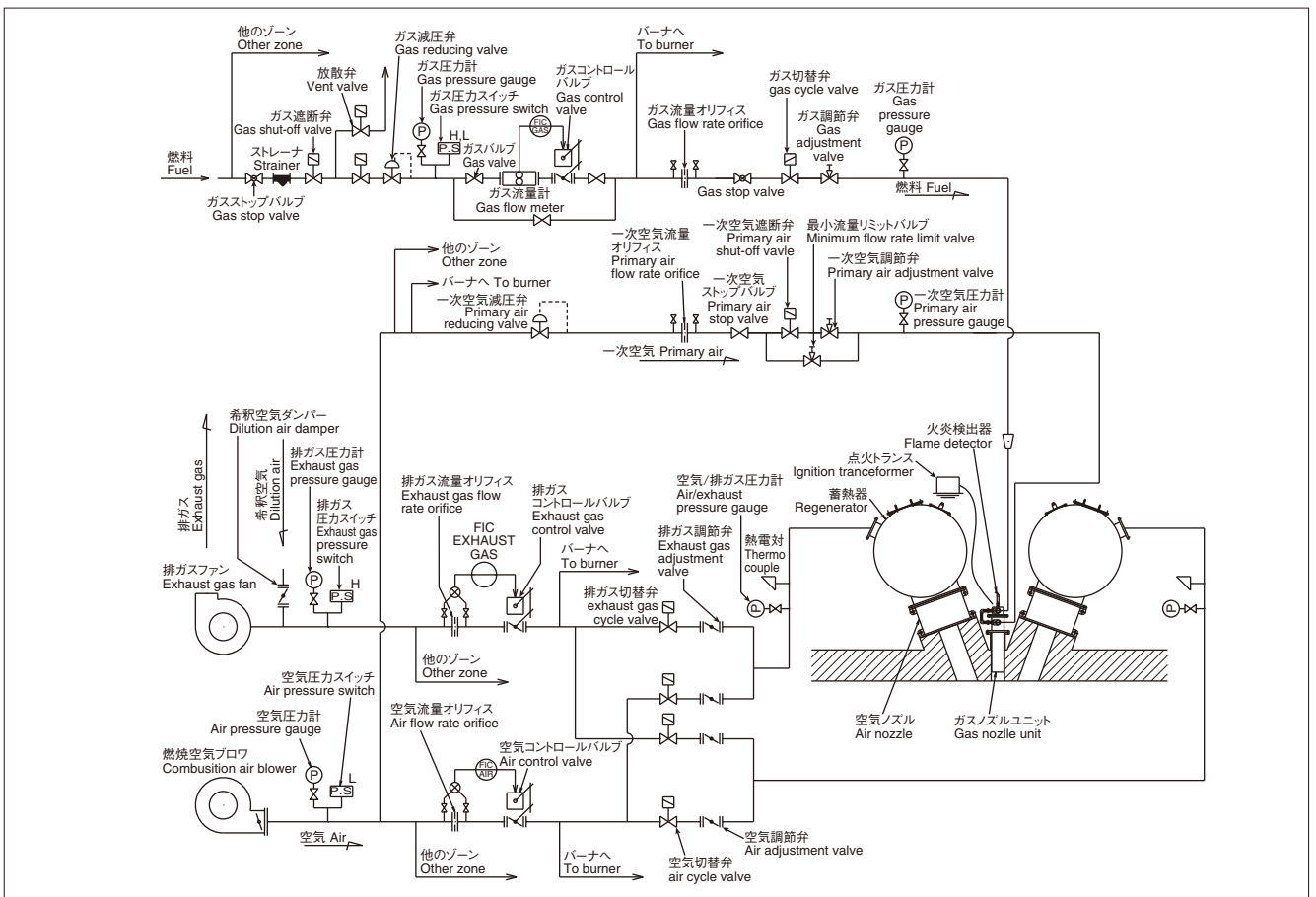

RCB-ES型セルフリジェネレーティブガスバーナ用配管フローシート PIPING FLOW PLAN FOR RCB-ES SELF REGENERATIVE GAS BURNER

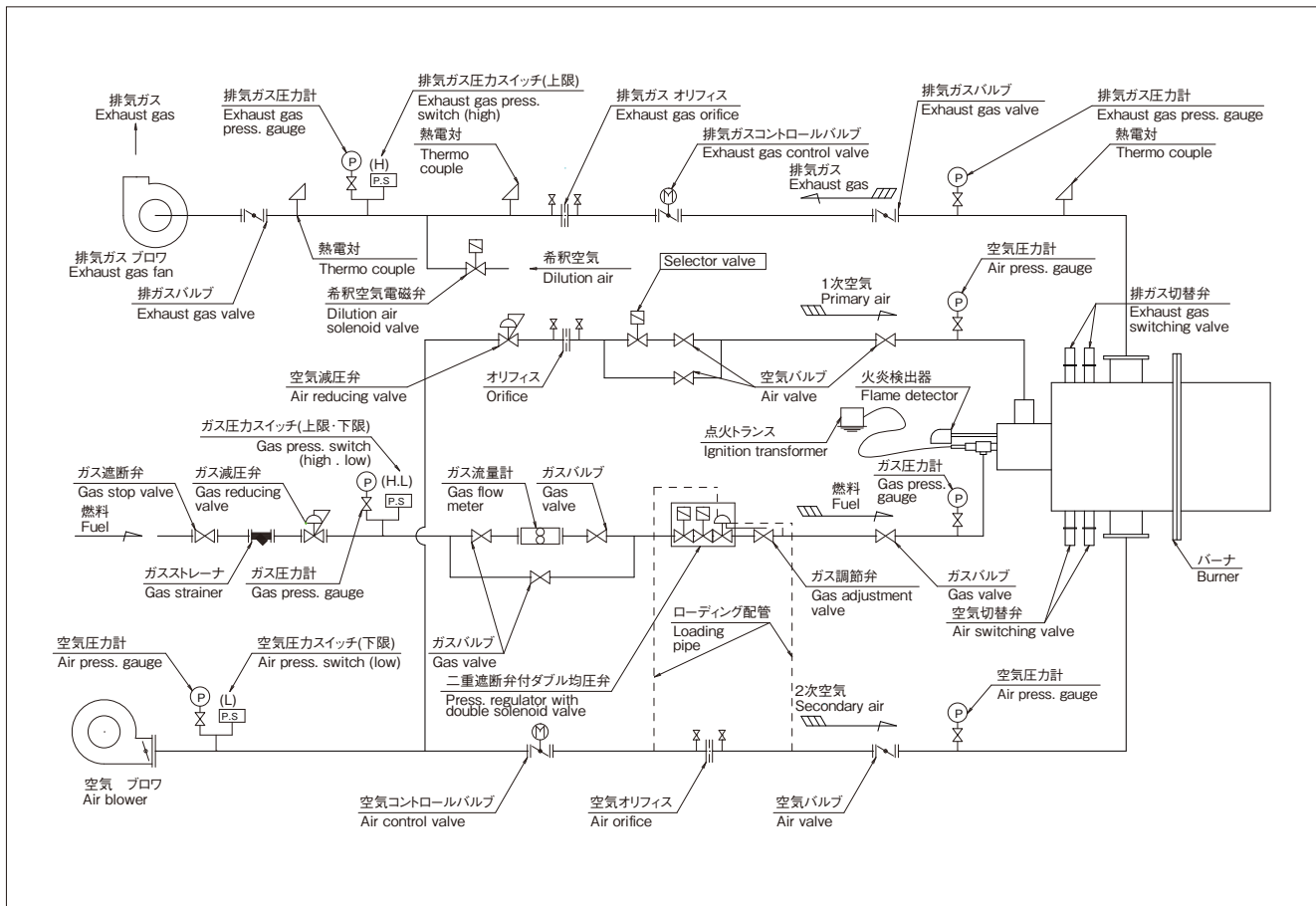

本製品に関する特許：特許第5785240号ほか83件

Patent for this product : JP5785240 and 83 other patents

※ 本カタログはSI単位を採用しています。従来単位とは下記数式にて換算してください。

*This catalog uses the SI units which can be calculated from the following formula:

● 1kcal/h=1.163×10⁻³kW 1kW=860kcal/h ● 1kcal=4.18kJ (1000kcal=41.8MJ) 1kJ=0.239kcal (1MJ=239kcal)

● 1mmH₂O=1kg/m²=9.81Pa (1kg/m²=98.1kPa) 1Pa=0.102mmH₂O (1kPa=102mmH₂O)



安全に関するご注意：ご使用の際は、取扱説明書をよくお読みの上、正しくお使いください。

SAFETY PRECAUTIONS : Read the instruction manual carefully before using the equipment.

サーモテックで未来をひらく

中外炉工業株式会社

CHUGAI RO CO., LTD.

URL <https://chugai.co.jp>

堺事業所 〒592-8331 堺市西区築港新町2丁4番
プラント事業本部 TEL(072)247-1440(直通) FAX(072)247-1441

東京支社 〒108-0075 東京都港区港南2丁目5番7号(港南ビル)
プラント事業本部 TEL(03)5783-3378(直通) FAX(03)5783-3368

名古屋営業所 〒450-0003 名古屋市中村区名駅南1丁目21番19号(Daiwa名駅ビル)
TEL(052)561-3561(代表) FAX(052)561-3566

Sakai Works :2-4,Chikko-Shinmachi,Nishi-ku,Sakai 592-8331,Japan
Tel +81-72-247-1440 Fax +81-72-247-1441

Tokyo Branch :2-5-7,Konan,Minato-ku,Tokyo 108-0075,Japan
Tel +81-3-5783-3378 Fax +81-3-5783-3368

Nagoya Sales Office:1-21-19,Meieki-Minami,Nakamura-ku,Nagoya 450-0003,Japan
Tel +81-52-561-3561 Fax +81-52-561-3566